

An Adjustable HVDC Power Supply using Integrated High Voltage Transformer with Some Protective & Controlling Features.

Nader N. Barsoum, Muhammad Muktadir Rahman

Abstract— We can produce variable/adjustable HVDC with a little arrangement using Fly back Transformer (IHVT), Tesla coil, car ignition coil & other type of step-up auto transformer found in microwave oven, X-ray units & in similar devices. This arrangement of circuitry is very reliable & light weight. In our experiment we made a power supply using Integrated High Voltage Transformer & try to give it several protective & controlling features to its driver circuitry to increase the longevity of the power supply. As far as the general run of small-scale electronics is concerned, EHT (extra high tension)/HVDC power supplies are used mainly for cathode ray tube (CRT) anodes and for some specialized purposes such as Geiger-Muller counters and photomultipliers. None of these applications calls for a large current drain. As an example, X-ray equipment may require 100 kVDC at a current of less than 1 A. Some of these EHT supplies such as those used for radio transmitters or particle accelerators demand very substantial currents. As an example, large radio transmitters may call for a 20 kVDC supply at several amperes of current.

Keywords — Adjustable, HVDC, Spark gap

This work was supported by the departments of Electrical and Electronic Engineering of UNIVERSITI MALAYSIA SABAH & American Intl. University- Bangladesh. The material of this paper was presented in part at the 3rd International Conference on Electrical Engineering and Informatics at Institut Teknologi Bandung, Bandung, Indonesia, July 17-19, 2011. Dr. Nader N. Barsoum is now with the department of Electrical and Electronic Engineering, FKJ, UNIVERSITI MALAYSIA SABAH (e-mail: nader@ums.edu.my). Muhammad Muktadir Rahman received his BSc. Degree in Electrical and Electronic Engineering from American Intl. University- Bangladesh, Dhaka 1213, Bangladesh in 2012. He is now doing Master of Engineering in Electrical & Electronic Engineering at the Dept. of EEE, FKJ, UMS, Jalan UMS, 88400 Kota Kinabalu, Sabah, Malaysia. (Corresponding author. Tel. +601123127261; e-mail: rumirahman1988@yahoo.com).

I. INTRODUCTION

There is no precise definition of what is now meant by EHT (extra high tension)/HVDC, but the original idea was that valve operated equipment could normally be expected to use voltage levels up to 500 VDC and anything higher than this was EHT, whether for a valve transmitter circuit, a TV cathode ray tube, X-ray tube or high voltage test equipments. The typical Fly back Transformers (IHVT) used in TV sets are similar to those high frequency transformers which are used in SMPS supplies. Using these Fly back Transformers, one can build a HVDC supply. The circuit is known as *flyback power supply* (see Fig. 1) which is similar to SMPS supplies. EHT supplies for laboratory use require considerably better stabilization than those used for TV sets, but the general principles follow much the same lines as are used in SMPS supplies.

II. EXPERIMENTS

We have implemented the circuit (Figure: 1) on bread board & PCB with necessary power supplies. Where Q_1 and Q_2 are driver and output transistors respectively. The output transistor is operated as an electronic switch, which when forward biased, saturates to close and on reverse biasing cuts-off to cause an open circuit. When in saturated mode, it has to deliver large bursts of power to the secondary coil of FBT.

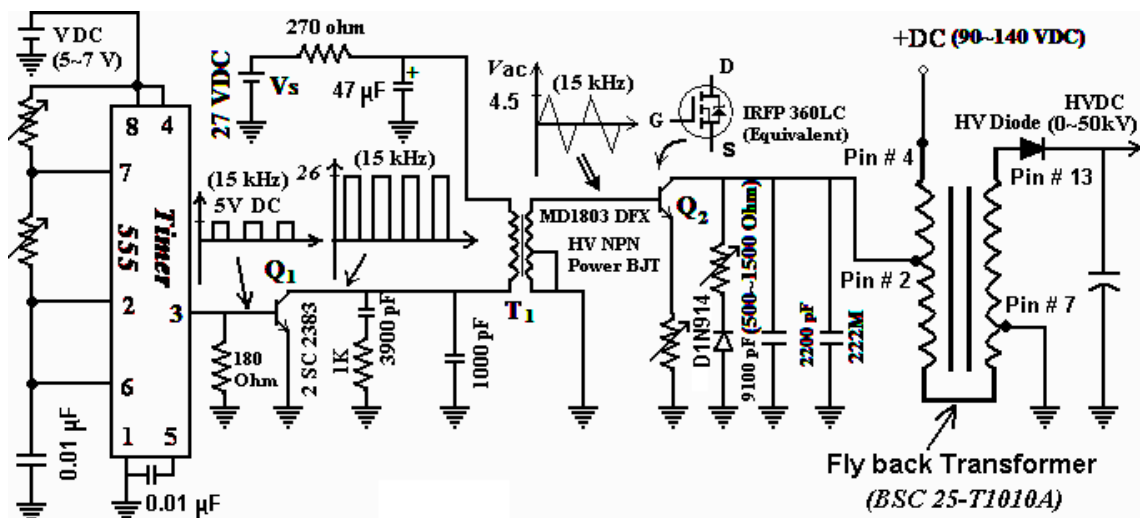

Figure: 1 Driver Circuit

Therefore, it is of great importance that the controlling voltage waveform fed to the base of Q_2 shall always be large enough to firmly turn it 'on' yet also sufficiently negative to reverse bias it when required to be cut-off. The transistor Q_1 is also operated as an electronic switch and triggered into conduction by positive pulses applied at its base. These pulses are received from the oscillator which is formed by 555 timer IC. When Q_1 is saturated its collector is nearly earthed and when turned-off, the collector voltage rises to about the same value as the supply voltage (V_s). Thus the waveform appearing at the collector of Q_1 takes the form of a series of square wave or rectangular pulses of amplitude nearly equal to V_s . These are fed at the base of Q_2 through coupling (step-down) transformer T_1 . The coupling transformer has a primary-to-secondary turns ratio of about 6:1 designed to match the high output impedance of Q_1 into the low impedance base circuit of Q_2 . The high step-down turns ratio also ensures that a negative pulse of about 5V can be applied to the base of Q_2 when it is desired to turn it off. The connections of T_1 are so arranged that the 'turning-on' of Q_1 causes Q_2 to 'turn-off' and conversely. Output transistor, Q_2 is a class "C" amplifier. Basically the amplifier operates like a switch, operating at a frequency from 1 kHz to several kHz. It operates at either saturation or cutoff. Some of these supplies use a bipolar transistor, while others use a MOSFET power transistor to pulse dc current through the primary of the IHVT [1],[6].

III. RESULTS AND OBSERVATION

Flyback transformers cannot be connected to the mains directly. They start working at a frequency of about 1 kHz, whereas the mains have only 50Hz. The higher frequency has many advantages, such as smaller and lighter cores, smaller caps for rectifiers etc. We vary frequency of the square wave (received from the oscillator) from 1.5 kHz to 82.5 kHz (with a variable duty cycle from 48%-90%). If we increase frequency of the Oscillator then the arc (at the secondary side of Fly back transformer and the spark gap between EHT cord and ground lead is approximately 1cm which indicates a spark-over voltage with a peak of 30 kV in air at 20°C and 760 torr pressure) [2] seems more thick with less whining which indicates an decrease in EHT/HVDC (Fig. 7). If we decrease frequency of the oscillator then the diameter of the arc will become thinner with a hissing sound which indicates an increase in EHT/HVDC (Fig. 2).

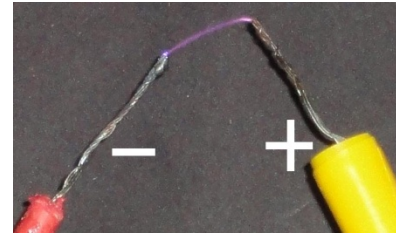

Figure: 2 Spark Gap indicating an increase in HVDC

Arc will not sustain if the frequency of the oscillator is less than 1.5 kHz. If we increase duty cycle (%) of the square wave (received from the oscillator) then the arc at the secondary side of FBT becomes thinner. If we decrease duty cycle (%) of the square wave of the oscillator then the arc at the secondary side of FBT seems very thick [9,10]. In our experiment when the duty cycle of the square wave of the oscillator is $\geq 98\%$, thin arc vanished suddenly. In addition to higher voltage requirements, some applications need more current and also some degree of stabilization. The current requirement is met by using larger currents in the primary of the coupling transformer (T_1) so that the amount of power that is switched through Q_2 is substantially higher. Output or driver transistors may have collector voltages as low as 26 volts, but they will draw up to 1.0 ampere or more current. Therefore, transformer windings, rectifiers, and filter chokes of necessary power supplies need to have higher current ratings [5]. If alternating sine wave has applied at the base of Q_1 then it will damage the power BJT (Q_2) as well as the oscillator but before that it works for a while (like few seconds). If E_s (secondary voltage) of FBT is increased, it causes an increase in I_p (primary current) and thus damages Q_2 . Adding capacitors (912H, 222M) in parallel (Figure: 3) between collector & emitter/Drain & source of HV power BJT/ nMOS (Q_2) will decrease the voltage (EHT).

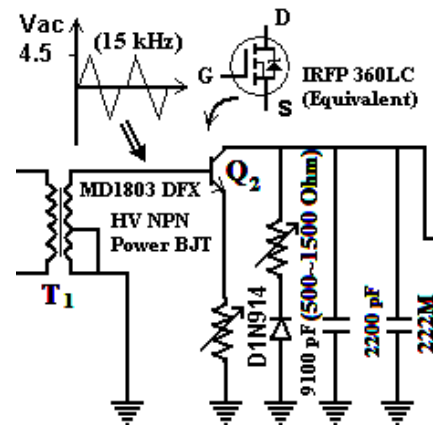

Figure: 3 Output Stage

We can increase HVDC by modifying the Fly back transformer primary winding by adding turns and extending the winding on the same core. Using voltage multipliers (triplers, generally), we

can reduce the high-voltage requirements of the FBT by a large factor. Voltage tripler modules are used to obtain this additional high voltage. This arrangement also minimizes the insulation requirements of the FBT. In HVAC system (conventional power system) line/phase lead becomes hot whereas an opposite thing happens in case of HVDC. In HVDC supplies, ground lead becomes too hot and it melts down during running a load of high R (Fig. 7). Finally the overall results will be optimum if we use an oscillator which produces less noisy pulse (here square wave).

IV. PROTECTIVE & CONTROLLING FEATURES

Although there is an inbuilt damper diode in the power BJT/nMOS (Q_2), we have used an extra 2W diode (polarity inconsequential). The resistor in series with this diode can not have a value less than $500\ \Omega$ to avoid damage to the resistor. This is critical in limiting the magnitude of the peak value of the collector emitter voltage during excessive arcing. Thus protective features of the entire schematic shown in figure: 4 ultimately comes down to the D1N914 and its series resistance which clearly brings significant changes in EHT [6]. Increasing the value of R_e , we can make the Q_2 more sustainable.

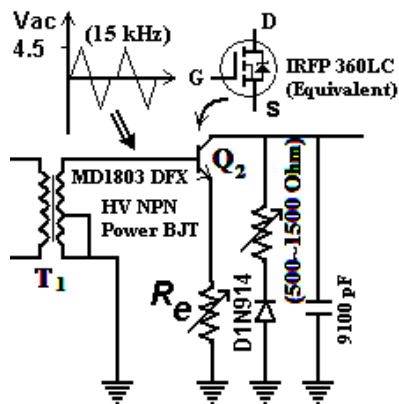

Figure: 4 Output Stage

Using power MOSFET as Q_2 one may achieve performance much superior to using bipolar power transistors. Since the best performance characteristics of the MOSFET come forth when the device is operated at very high frequencies (normally 100 KHz and above), certain design precautions must be taken in order to minimize problems, especially oscillations. There is one simple design rule associated with MOSFET application which will prevent the transistor from oscillating when used in high frequencies. First, minimize all lead lengths going to the MOSFET terminals, especially the gate lead. If short leads are not possible, then the designer may use a ferrite bead or a small-value resistor in series with the gate of the MOSFET. Either one of those elements when placed close to the transistor gate will

suppress parasitic oscillations. Another important thing to remember is the fact that the silicon oxide layer between the gate and source regions can be easily perforated and therefore permanently destroyed if the gate-to-source voltage exceeds manufacturer's specifications. Practical gate voltages have a maximum value anywhere from 20 to 30 V. Even if the gate voltage is below the maximum permissible value, it is advisable to perform a thorough investigation to make sure that there are not any fast rising spikes, caused by stray inductances, which may destroy the oxide layer of the MOSFET. Also it is very important to realize that in the case of inductive reactance/inductance, the ohmic opposition is proportional to the frequency. The frequency of the applied current has a very significant effect on the operation of magnetic components like transformers and inductors. The higher the frequency, the faster is the rate at which the current changes. For example, if the applied current had a frequency of 120 cycles per second instead of 60, the current flowing through the coil would change twice as fast. The faster the current changes, the faster the magnetic field about the inductor expands and collapses. Because the magnetic lines of force move so much faster, they induce a higher emf in the coil. In other words, the faster moving magnetic lines cause the coil to offer an even higher opposition to the flow of AC current and therefore the lower is the current flow through the single winding of the auto transformer which makes the very thin wire of the single winding of IHVT more sustainable. There are several advantages to designing converters working at, say, 100 KHz rather than 20 KHz, the most important being reduced size, weight and the acoustical noise. The power MOSFET offers the designer a high speed, high power, high voltage device with high gain, almost no storage time, no thermal runaway and inhibited breakdown characteristics. We can add a distant controlling feature by replacing R_e and R_b with some light dependent resistor or photo conductive cell (Fig. 5). Then by controlling the intensity of the incident light to those photo resistive parts, we can control the driver circuitry (Fig.1). Finally we need to control the intensity of the incident light from a distance to achieve our goal.

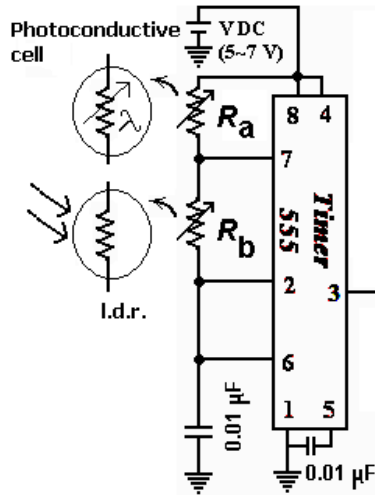

Figure: 5 Oscillator

V. MEASUREMENT & INSTRUMENTATION

It is not possible to check directly the voltage pulse waveform at the anode of the high voltage rectifier, because the peak-to-peak amplitude of the pulse may be as high as 50KV. It is possible, however to see the pulse on a scope by bringing the scope probe near the anode lead of the rectifier. There is enough capacitive coupling to give an indication. We have also used a HV probe (Fig.6), connected with a DMM to measure HVDC. A spark gap (Fig.7) can be used for measurement of the peak value of the HVDC [7]. Air is a poor conductor of electricity. However if two conductors are separated by a small gap of air /gas, it is possible to make the electric current jump across the gap. 1 cm spark gap in air between EHT cord (pin # 13) & ground lead (pin #7) indicates a spark over voltage of 30 KV (peak) approximately. If the arc gap becomes too long, the applied voltage could be insufficient to maintain the arc and it breaks off. A modern digital multimeter with functions of measuring actuating quantities like, frequency and duty cycle is adequate for this experiment.



Figure: 6 HV Probe

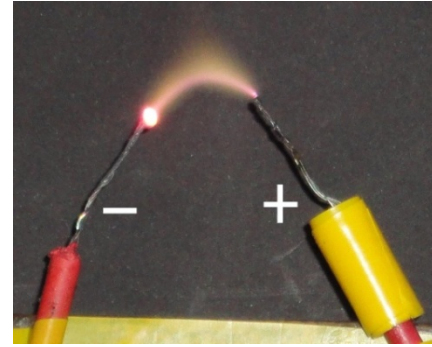

Figure: 7 Spark Gap indicating decrease in HVDC

VI. CONCLUSION

The circuit works and is great for many things, such as drawings arcs, Jacob's ladders, charging capacitors, running a HV cascade (not recommended for beginners!), powering plasma globes & lifter, and even powering a small Tesla Coil. Any work on EHT supplies should be carried out with great cautions, because capacitors in the circuit may have been charged to several kilovolts [3]. Even though EHT supplies may be current limited and capacitors values are small compared to the electrolytic capacitors that are used in low voltage supplies, the discharge of a capacitor can represent a large amount of energy which can prove fatal. Switching off and discharging capacitors may not be safe either, because some types of capacitors exhibit a form of voltage hysteresis, so that after being discharged they can build up voltage again and when work is to be carried out on an EHT supply, all capacitors should be discharged properly.

ACKNOWLEDGMENT

The authors would like to acknowledge for the financial support and providing excellent research facilities by FKJ, UNIVERSITI MALAYSIA SABAH.

REFERENCES

- [1] Robert E. Iannini, *Build your own working Fiber optic, Infrared, and Laser Space-Age Projects*, TAB books, 1987, ISBN: 0-8306-2724-3.
- [2] M Naidu, V. Kamaraju, *High Voltage Engineering*, ISBN: 9780070669284 , Nov. 2008.
- [3] R.A.Penfold, *Electronics Build & Leran*, First Indian Edition, 1990.
- [4] Alexander Schure, *Basic Television*, Vol. 4, Reprint- 1989.
- [5] Jack Darr, *Transistor TV Servicing Made Easy*, 3rd INDIAN Reprint- 1983.

- [6] Arvind M. Dhake, *Television & Video Engineering*, McGraw Hill, 2006.
- [7] Bernard Grob, Charles Herndon, *Basic Television and Video Systems*, March 1998.
- [8] Etienne Sicard, Sonia Delmas Bendhia, *Basics of CMOS Cell Design*, McGraw Hill, 2007.
- [9] Howard M. Berlin, *The 555 Timer Applications Sourcebook with Experiments*, E & L instruments, 1985, ISBN: 81-7635-790-6
- [10] Robert F. Coughlin, Frederick F. Driscoll, *Operational Amplifiers and Linear Integrated Circuits*, prentice-hall, 2001, ISBN 81-203-2096-4